

# Project 17123EZ: Wall Shelf with Pegs



*Pine, cherry, oak, or walnut: no matter what wood you choose, a small wall shelf such as this makes a useful addition to just about any room in the house.*

## Wall Shelf Materials List

Part	Description	Size	Number Required
A	Side	3/4" x 7-1/2" x 11"	2
B	Stretcher	3/4" x 2" x 27-1/2"	1
C	Pegboard	3/4" x 2" x 30"	1
D	Shelf	3/4" x 9-1/4" x 36"	1
E	Peg	see <b>Figure 1</b>	6

# Wall Shelf Complete Schematic

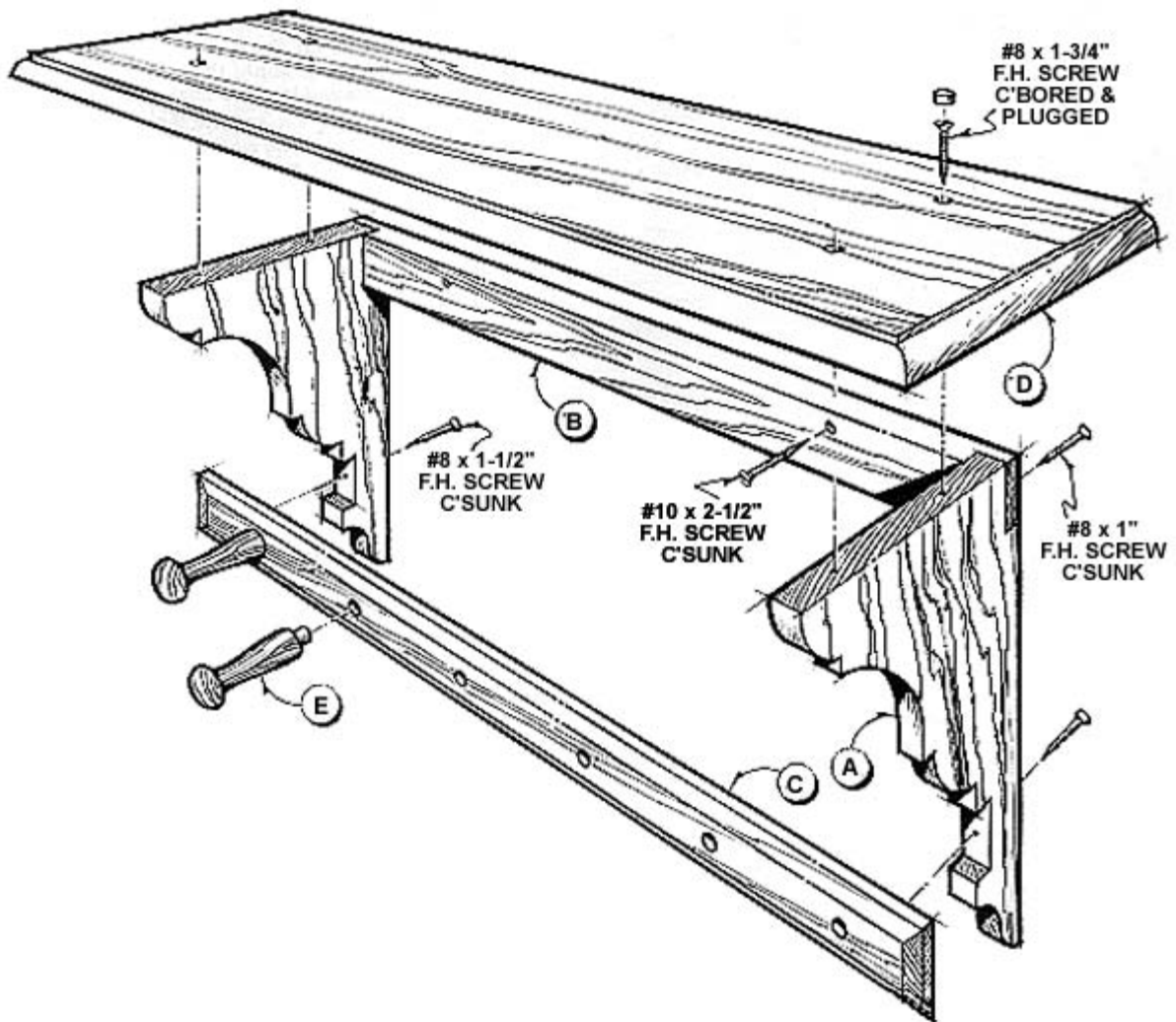
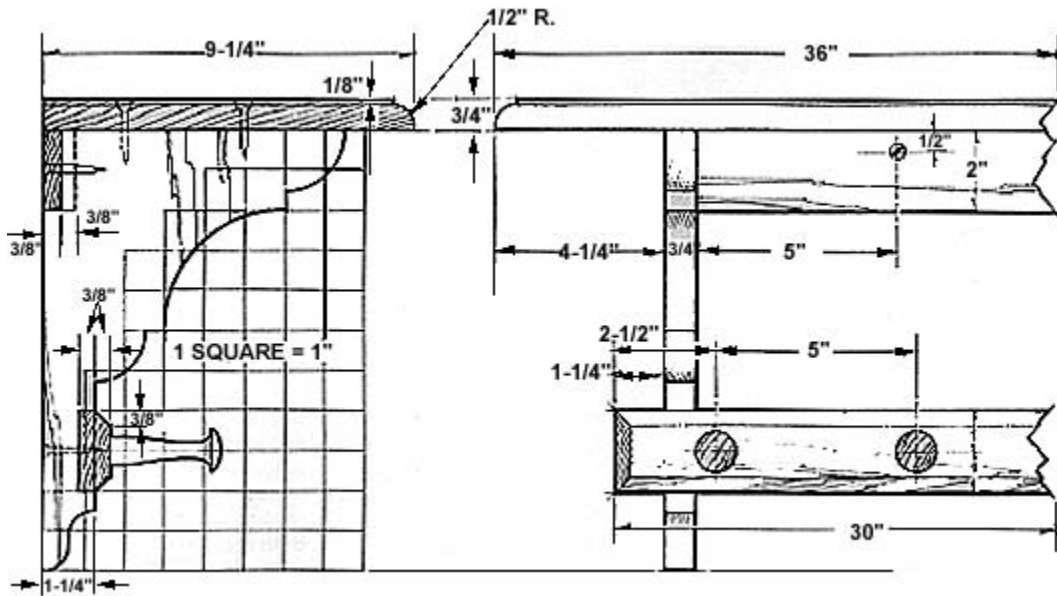

# Wall Shelf Instructions

## Step 1: Make the Sides (A)

1. Cut two pieces of 3/4" stock to 8" wide by 12" long. **NOTE: The width and length dimensions allow extra stock.**
2. Mark the curved profile from the grid pattern shown in the schematic to **just one** of the sides (A).
3. Use a band saw or jigsaw to make the curved profile cut, **staying slightly on the waste side of the line.**
4. Sand the edge of the completed cut smooth.
5. Use the completed side piece (A) profile to trace the contour on the remaining side (A).
6. Repeat substeps 3 and 4 for the remaining side (A).

## Step 2: Make the Notches in the Sides (A) to Accept the Stretcher (B) and Pegboard (C)

1. Layout and mark the location of the 3/8" deep X 2" long notches on the sides (A) that accept the stretcher (B) and the pegboard (C).
2. Cut the stretcher notch by using a fine-toothed hand backsaw **OR** a table saw in conjunction with a dado-head set to make a 3/8" cut and miter gauge to pass the stock, on edge, through the cutter. **NOTE:** If you use the table saw method, you will need to make three or four passes to establish the 2" length.
3. Use a chisel and mallet to cut the pegboard notch.

## Step 3: Make the Stretcher (B)

1. Cut the stretcher (B) to the correct length and width (see the materials list).
2. Use the table saw and dado head to cut the 3/8" deep by 3/4" wide rabbets on each end of the stretcher (B).
3. Bore 3/16" diameter shank holes at each rabbet.
4. Bore 3/16" diameter shank holes at a point 5-3/4" from each end (see schematic).
5. Counter sink the holes cut in substeps 3 and 4 to accept the flathead wood screws.

#### Step 4: Make the Pegboard (C)

1. Rip the pegboard (C) to a width that will fit snugly in the notches.
2. Cut the pegboard (C) to a length of 30".
3. Cut the bevel for each of the four edges using the table saw with the blade set at 45 degrees.
4. Lay out and mark the location of the six peg holes.
5. Use a drill press to bore out the peg holes.
6. Turn the pegs according to the profile shown in **Figure 1**, or purchase pre-made pegs with these dimensions.

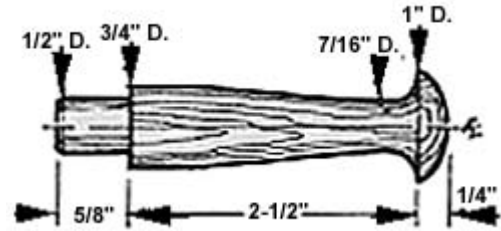

**Figure 1. Peg Dimensions**

#### Step 5: Make the Shelf (D)

1. Use a 36" length of 1" x 10" (which will measure 3/4" thick x 9-1/4" wide) stock to make the shelf (D).
2. Use a router equipped with an edge-guide and a 1/2" radius bearing-guided round-over bit to cut the molded edge of the front and side edges of the shelf (D).

#### Step 6: Sand, Assemble, and Finish

1. Final sand all parts
2. Glue the six pegs in place.
3. Apply two coats of Minwax's Colonial Maple.
4. Follow with three applications of Watco Danish Oil.
5. Space the mounting screws 16" apart to permit the shelf to be secured to wall studs.
6. Use 2-1/2" x #10 screws placed 16" apart to secure the shelf to wall studs.  
NOTE: The 2-1/2" screw length allows for the 3/4" stretcher thickness plus 1/2" thick dry wall.

---

These plans were originally published in Volume 11, Issue 6 of *The Woodworker's Journal* (Nov./Dec. 1987, pages 52-53).