



TV Cabinet

Plan No. 918

Copyright U-Build, Inc., 2003.
All rights reserved. Printed in the U.S.A.

Designed for a standard 32-inch TV (and some 36-inch TVs), this handsome television cabinet features pocket doors for unobstructed viewing from any angle. Generous accessory shelves will accommodate a cable or satellite decoder, a VCR or DVD player, a home theater system, a video game system and more.

Overall, the television cabinet measures about 60 inches tall by 42 inches wide by 22 inches deep. The interior cabinet will accommodate a TV that measures 33 inches wide by 33 inches tall.

Bill of Material

Quantity	Size	Material	Item
3	3/4" x 48" x 96"	plywood	A, B, C, D, L, N, Q, S, U
1	1/4" x 48" x 48"	plywood	X, Y
2	3/4" x 8" x 120"	lumber of choice	E, F, G, H, I, M, O, P, R, T, V, W, Z
1	3/4" x 3/4" x 96"	moulding (see Figure 3)	J, K
2 sets (right and left)	20"	pocket door hardware	
2		magnetic touch catches (optional)	
32	3/8" x 2"	dowels	
1 box	1 1/4"	finish nails	
1 box	3/4"	finish nails	
1 can		wood filler	
1bottle		wood glue	
1 quart		finish of choice*	

NOTE: Hardwood lumber sizes are provided as a base for your own calculations. Individual boards vary in appearance and defects, which may affect your cutting layout. Also, leftover scraps can often be reglued and used for other parts.

*We used a fast-drying polyurethane clear satin finish over a medium stain.

Cutting Schedule

Item	Qty	T	W	L	Material	Item	Qty	T	W	L	Material
A	2	3/4"	21 1/4"	59 1/4"	plywood	N	1	3/4"	19 3/4"	33"	plywood
B	1	3/4"	40 1/2"	59 1/4"	plywood	O	2	1/4"	3/4"	19 3/4"	lumber of choice
C	1	3/4"	22"	42"	plywood	P	1	1/4"	3/4"	33 1/2"	lumber of choice
D	1	3/4"	20 1/2"	40 1/2"	plywood	Q	2	3/4"	19 3/4"	32"	plywood
E	1	3/4"	2 3/4"	38"	lumber of choice	R	2	1/4"	3/4"	32"	lumber of choice
F	1	3/4"	2"	38"	lumber of choice	S	1	3/4"	19 3/4"	9 1/4"	plywood
G	2	3/4"	2"	59 1/4"	lumber of choice	T	1	1/4"	3/4"	9 1/4"	lumber of choice
H	2	3/4"	1 11/16"	23 11/16"	moulding	U	1	3/4"	5 1/4"	32"	plywood
I	1	3/4"	1 11/16"	45 3/8"	moulding	V	6	3/4"	2"	14 7/8"	lumber of choice
J	2	3/4"	3/4"	22 3/4"	moulding	W	4	3/4"	2"	50 1/16"	lumber of choice
K	1	3/4"	3/4"	43 1/2"	moulding	X	2	1/4"	15 5/8"	31 11/16"	plywood
L	2	3/4"	19 3/4"	16"	plywood	Y	2	1/4"	15 5/8"	13 7/8"	plywood
M	2	1/4"	3/4"	16"	lumber of choice	Z	4	3/4"	1 1/4"	20 1/2"	lumber of choice

NOTES

1. Read manufacturer's instructions before operating equipment.
2. **Always** wear safety glasses.
3. We used maple for this project, but oak, pine or birch will work equally well.
4. If you choose to install magnetic touch catches on the project, attach a 2" x 4" mounting block to the center of the back side and flush with the bottom of board (E).
5. Once the project is finished, back panel (B) may require a cut-out to accommodate your television.

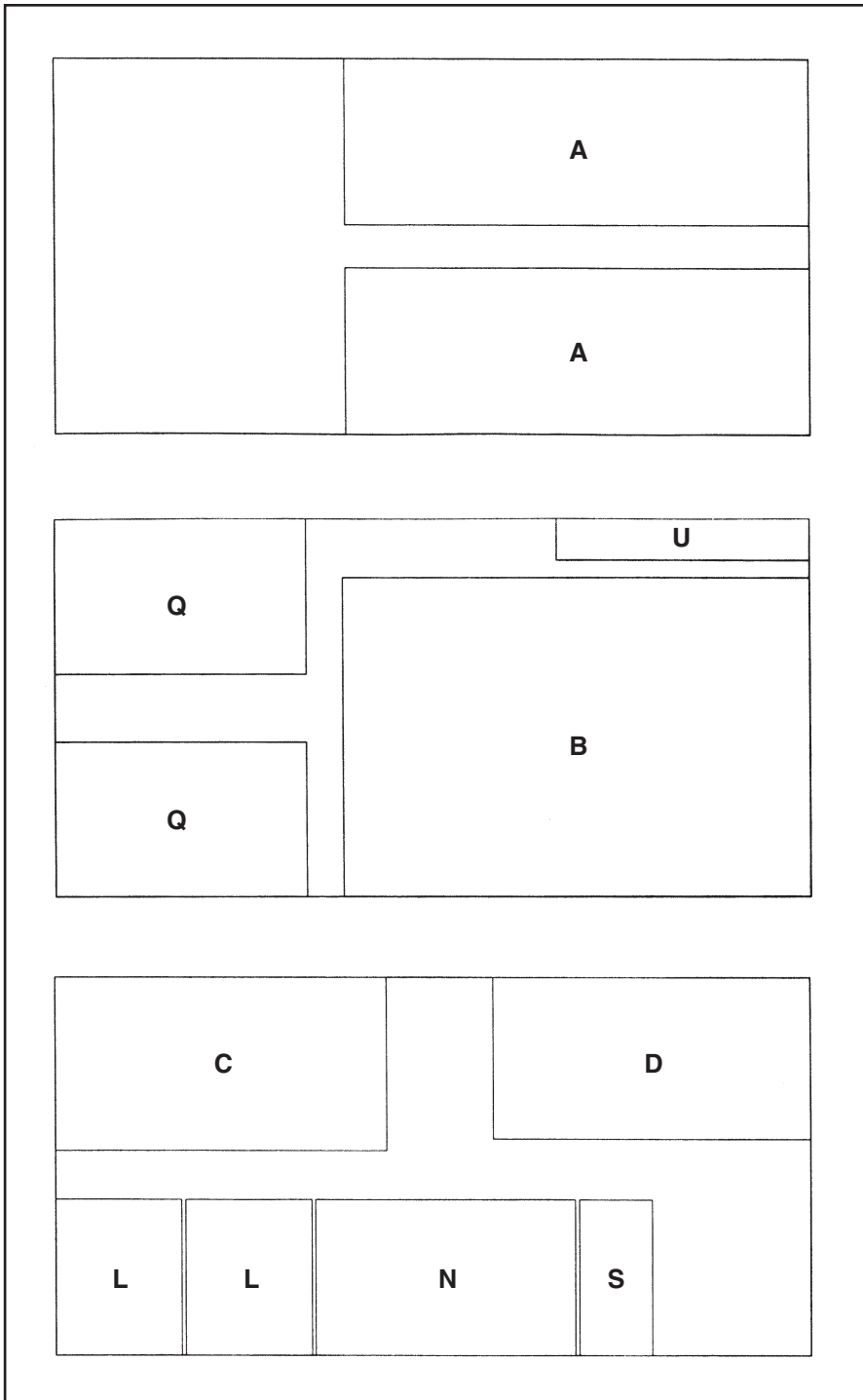

**3/4" x 48" x 96"
Plywood Cutting Layouts**

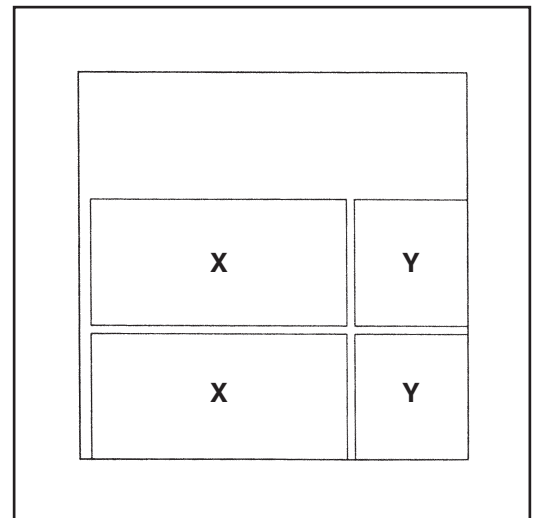

**1/4" x 48" x 48"
Plywood Cutting Layout**

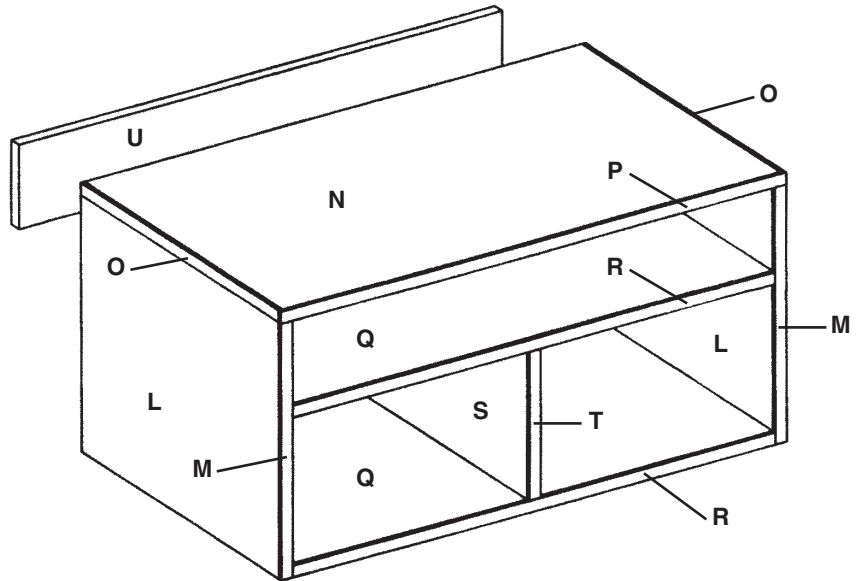
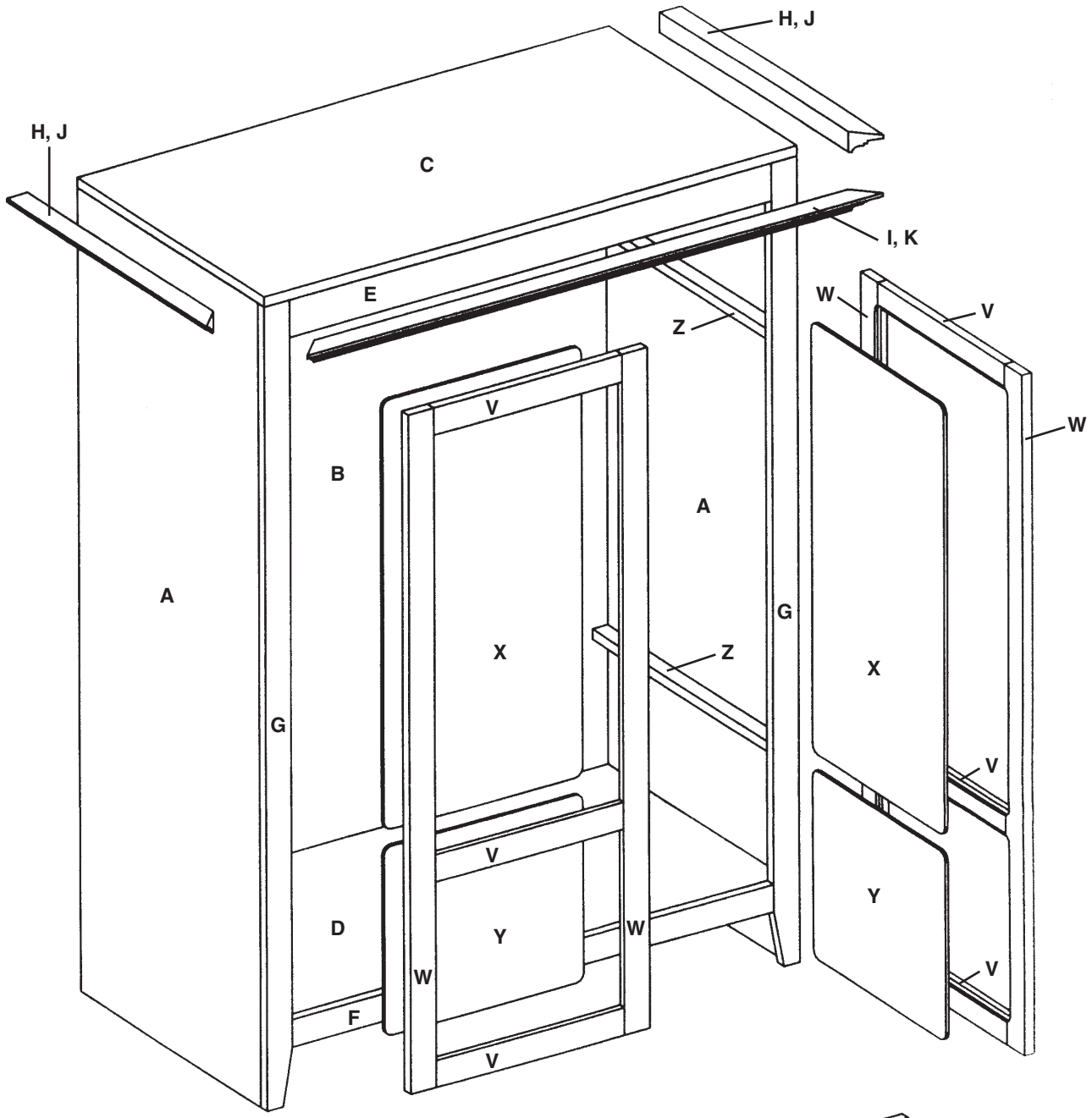

Isometric

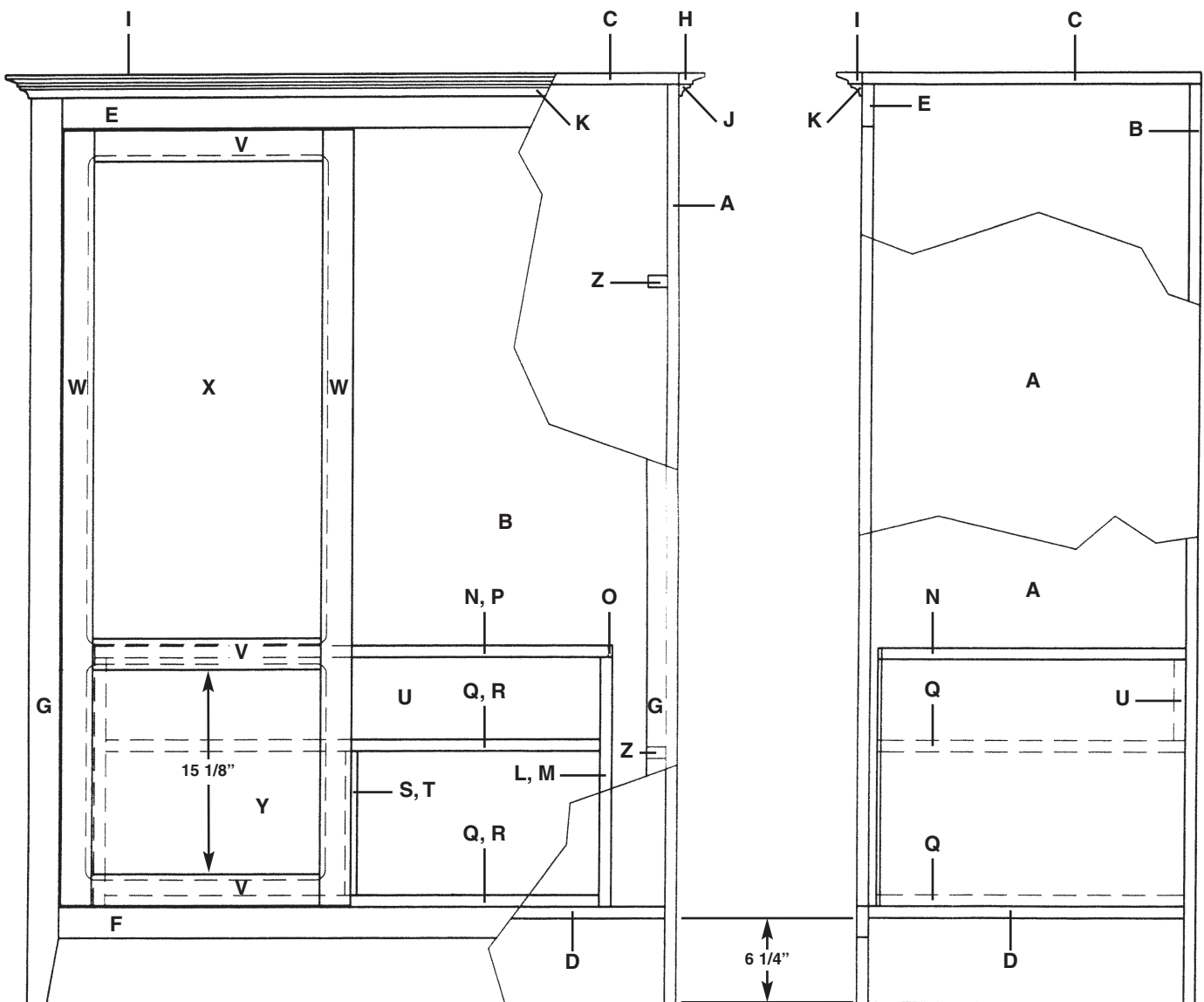
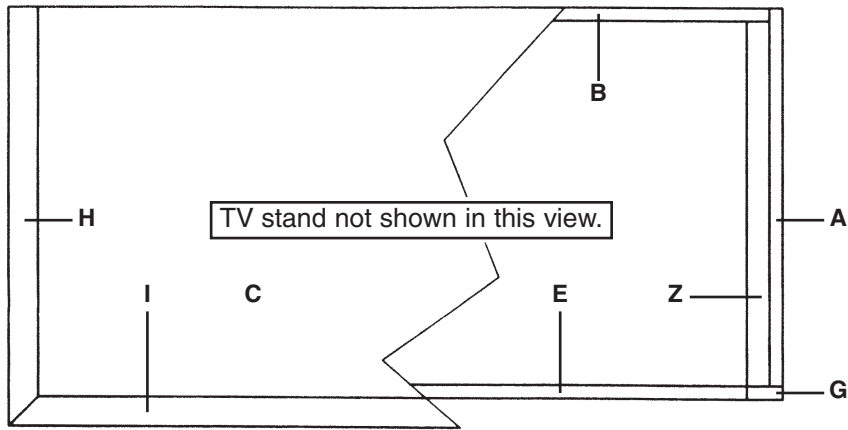

Figure 1
Front, Side & Top Views

Assembly Instructions

Page One

Read all instructions before beginning any work. Cut all material to sizes shown in cutting schedule.

1. Attach sides (A) to back (B) using glue and 1 1/4" finish nails. Refer to Isometric and Figure 1.
2. Attach top (C) to subassembly (A, B) using glue and 1 1/4" finish nails. Check for squareness. Refer to Isometric and Figure 1.
3. Attach bottom (D) to subassembly (A, B, C) using glue and 1 1/4" finish nails. Check for squareness. Refer to Isometric and Figures 1 and 2.

4. Cut legs on boards (G). Refer to Figure 2.

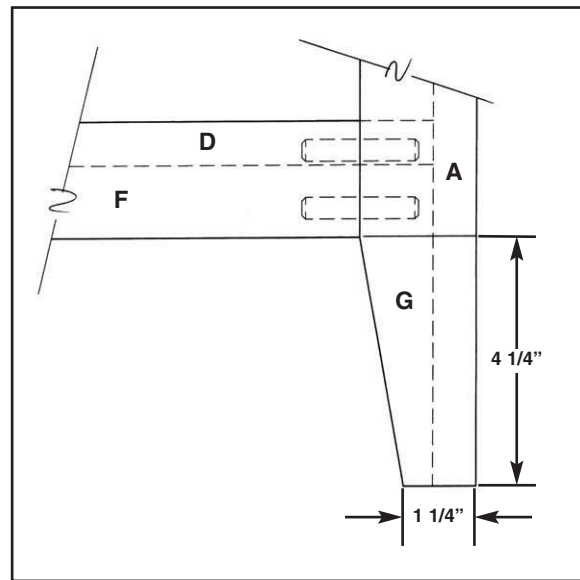
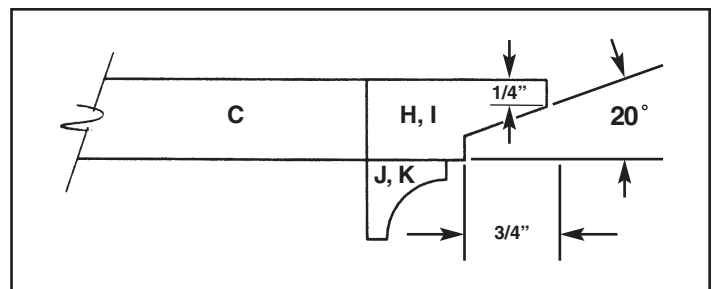

Figure 2
Leg Pattern

5. Assemble face frame boards (E), (F) and (G) using glue and 3/8" dowels. Check for squareness. Refer to Isometric and Figures 1 and 2.
6. Attach face frame (E, F, G) to cabinet subassembly (A, B, C, D) using glue and 1 1/4" finish nails. Check for squareness. Refer to Isometric and Figure 1.

7. Attach moulding (H), (I), (J) and (K) to cabinet using glue and clamps. Refer to Isometric and Figures 1 and 3.

Figure 3
Moulding Pattern



Assembly Instructions

Page Two

Read all instructions before beginning any work. Cut all material to sizes shown in cutting schedule.

Note: Steps 8 through 16 apply to the TV stand only.

8. Attach trim strips (M) to side boards (L) using glue and 3/4" finish nails. Refer to Isometric and Figure 1.
9. Attach trim strips (O) and (P) to top board (N) using glue and 3/4" finish nails. Refer to Isometric and Figure 1.
10. Attach trim strips (R) to shelf and bottom boards (Q) using glue and 3/4" finish nails. Refer to Isometric and Figure 1.
11. Attach trim strip (T) to divider board (S) using glue and 3/4" finish nails. Refer to Isometric and Figure 1.
12. Attach sides (L, M) to top (N, O, P) using glue and 1 1/4" finish nails. Refer to Isometric and Figure 1.
13. Attach bottom (Q, R) to sides (L, M) using glue and 1 1/4" finish nails. Refer to Isometric and Figure 1.
14. Attach divider (S, T) to the center of the underside of shelf (Q, R) using glue and 1 1/4" finish nails. Refer to Isometric and Figure 1.
15. Insert shelf and divider subassembly (Q, R, S, T) into box subassembly (L, M, N, O, P, Q, R) and attach to sides (L, M) and bottom (Q, R) using glue and 1 1/4" finish nails. Refer to Isometric and Figure 1.
16. Insert shear board (U) between top (N, O, P) and shelf (Q, R) and attach to sides, top and shelf using glue and 1 1/4" finish nails. Refer to Isometric and Figure 1.

17. Assemble door frame boards (V) and (W) using glue and 3/8" dowels. Check for squareness. Refer to Isometric and Figures 1 and 4.

Figure 4
Door Frame Construction

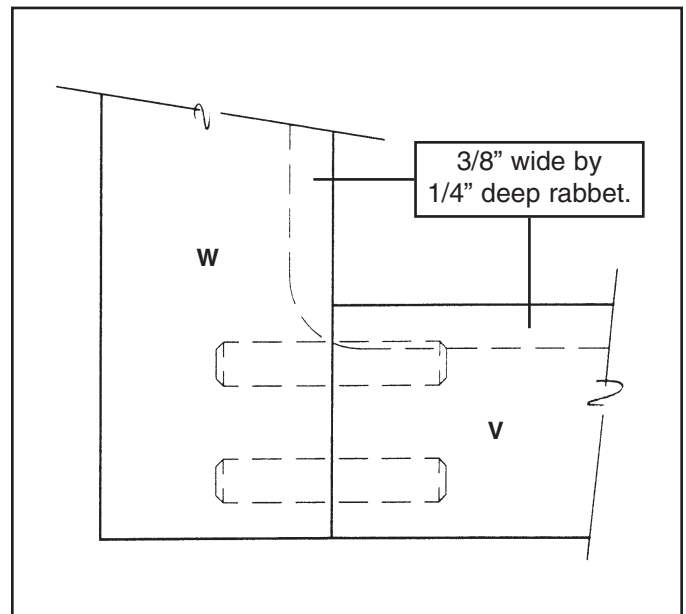

18. Cut a 3/8" wide by 1/4" deep rabbet on the inside back edges of door frames (V, W). Refer to Isometric and Figure 4.

Assembly Instructions

Page Three

Read all instructions before beginning any work. Cut all material to sizes shown in cutting schedule.

19. Insert door panels (X) and (Y) into rabbets in back side of door frames and attach using glue and clamps. Refer to Isometric and Figure 1.
20. Sand cabinet, doors and TV stand.
21. Apply finish to cabinet, doors and TV stand.
22. Using pocket door hardware to determine position, install hardware mounting boards (Z) to the inside of sides (A).
23. Install pocket door hardware on doors (V, W, X, Y) and hardware mounting boards (Z) per manufacturer's instructions.
24. Place TV stand inside cabinet.
25. If necessary, using your TV set as a guide determine size and position of hole to cut in back (B).