

WoodworkingTips.com

Weekly tips from the editors of *Woodsmith*, *ShopNotes*, and *Workbench*

Multi-Purpose Fence Sled

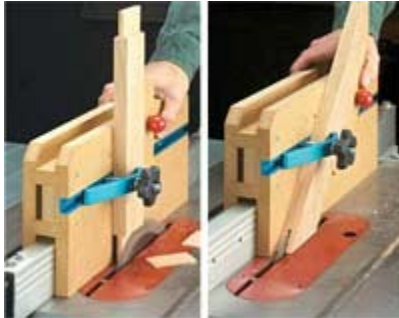

When it comes to cutting tenons on the end of a workpiece, I usually use the table saw fitted with a dado blade. The problem with this method is that the cheeks of the tenons can end up pretty rough.

To get tenons with smooth cheeks, you can use a standard blade and hold the workpiece on end. But, for this to work, you need a good way to control the workpiece and keep it from tipping.

To do this, I made a sled that rides on the rip fence, as you can see in the photo at right. This sled not only works great for cutting tenons, but I found that it can be used to cut spline grooves in miter joints as well.

Building the Sled

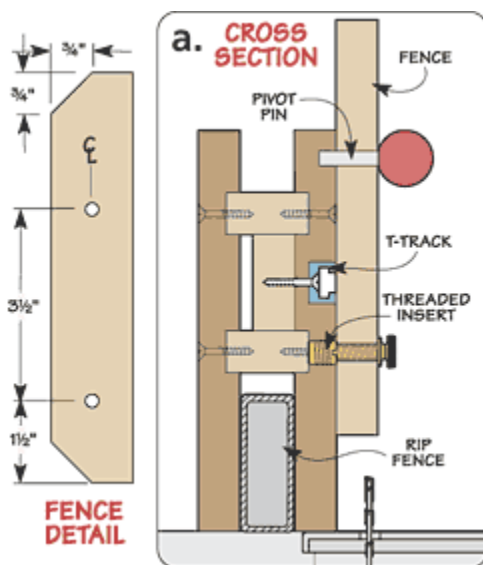

Best of all, the sled doesn't take much material or hardware to build. As you can see in the drawing below, the main section of the sled is a pair of $\frac{3}{4}$ " MDF faces that straddle the rip fence. A groove in the front face holds a length of T-track. The two faces are held together by a pair of spacers that are glued and screwed into shallow

grooves, as in detail 'a'. I also glued a block behind the front face to give the screws for the T-track something to bite into.

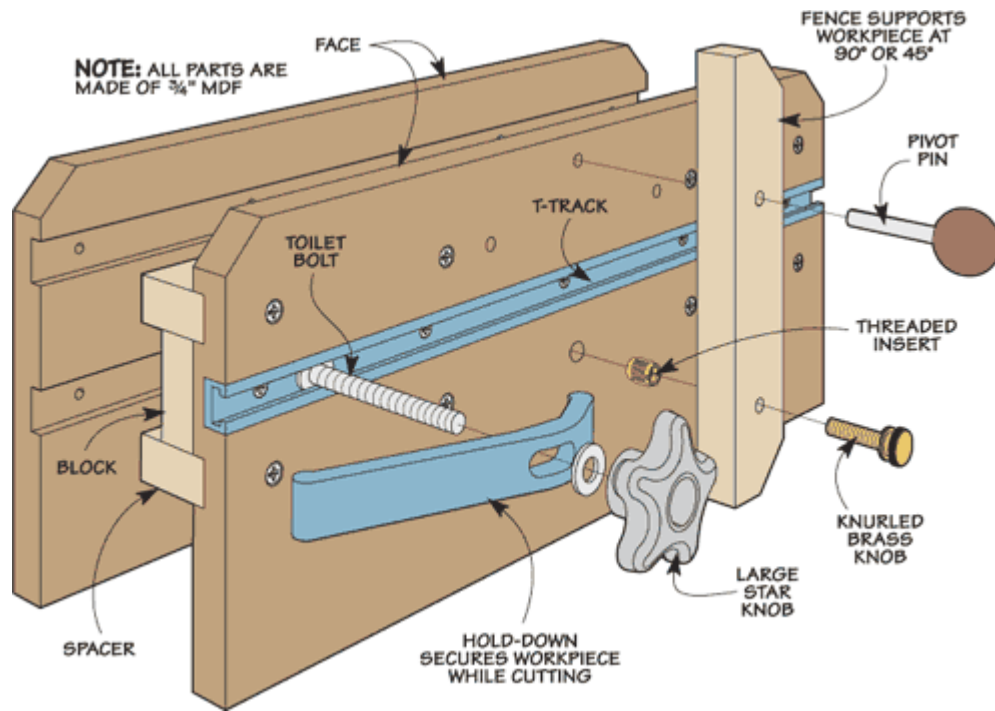

Pivoting Fence

To support the workpiece, I made a fence out of MDF. It's fastened on the lower end by a knurled brass knob. The top end can pivot to support either square or mitered workpieces. I drilled three holes to hold a pivot pin. Then to hold the workpiece secure while cutting, I attached a hold-down with a toilet bolt, washer, and knob.

Good Woodworking,

Phil Huber
Online Editor, *ShopNotes*

© August Home Publishing Company
2200 Grand Avenue, Des Moines, Iowa 50312