

## Make Perfect Mortises

Holding a workpiece against the table and fence when drilling out a mortise at the drill press can be a hassle. I solved the problem with this hold-down jig made from an inline skate wheel bought at a sports store.

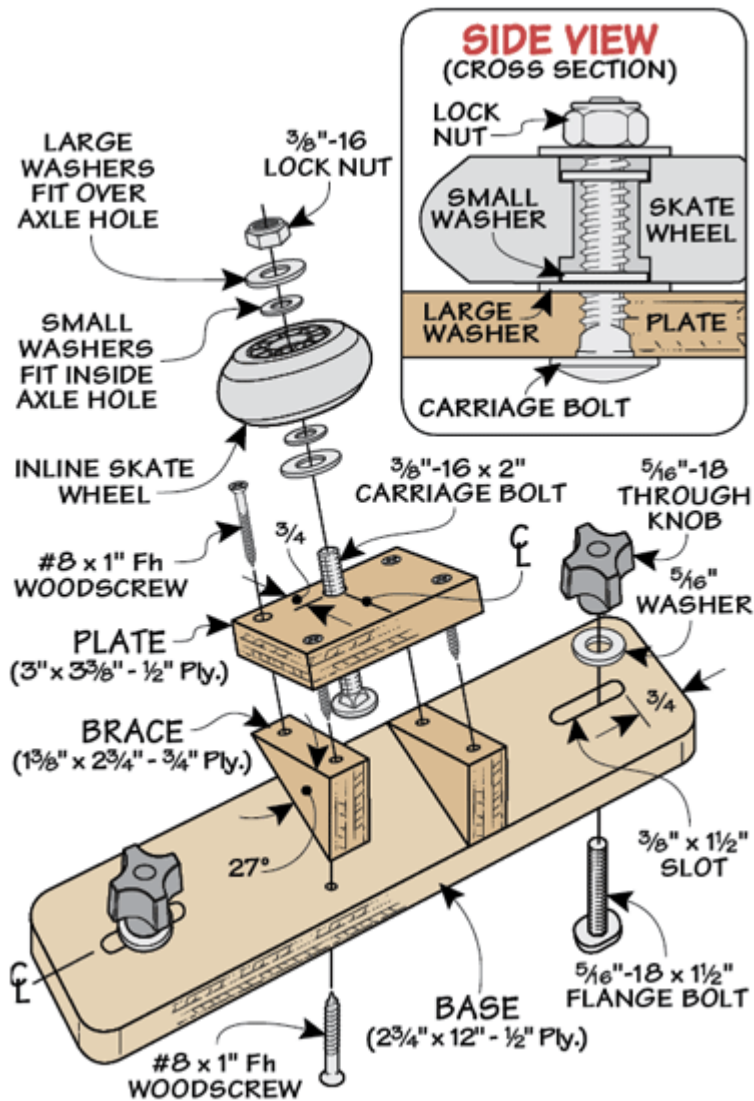

Size the base to fit your drill press table. A bolt serves as the “axle” and a series of washers keeps the wheel centered on the bolt and spinning freely. Just snug the hold-down against the workpiece before drilling.

