

Coffee Mill Plan

ezplan



Decorative cast iron coffee mill grinding mechanisms fit our easy to build coffee mill plan. Choose from [wheel style mechanism](#) (shown at left in photo) or [crank mechanism](#) (right in photo).

Base

- A. Base
- B. Sides
- C. Front
- D. Back
- E. Top (for wheel mechanism only)

Drawer

- V. Front
- W. Sides
- X. Back
- Y. Bottom
- Z. Knob

Mechanism

(41859 and 41846 Sold Separately)

- 1. Bowl
- 2. Cover (with handle)
- 3. Crank handle
- 4. Cast iron nut
- 5. Wing nut

Cutting Procedures

1. Cut all pieces to sizes as indicated on Coffee Mill Dimensions below.
2. Rabbet parts **C** and **D** as shown to accept side **B**.
3. Router outside edges of base piece **A** (and top piece **E** if building for #41846 Cast Iron Wheel Mechanism) with Roman Ogee bit (#91639) or decorative bit of your choice.

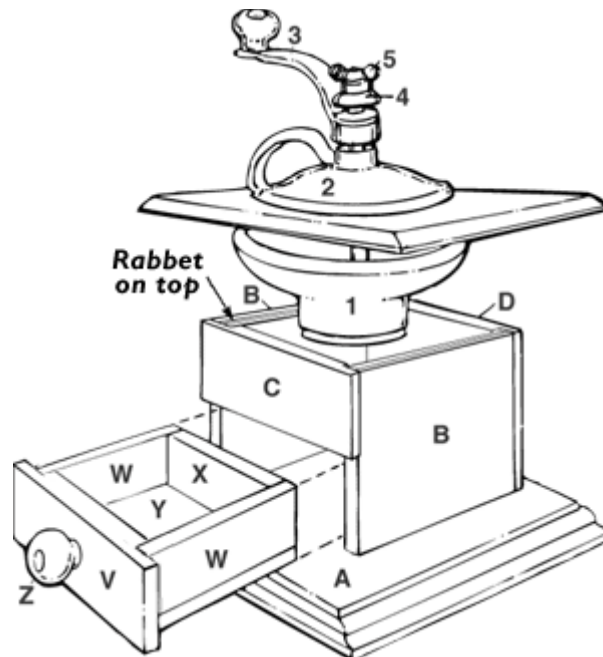

Shown with 41859 Crank Mechanism

4. Drawer side piece **W** and drawer back piece **X** require 1/8" groove 3/16" deep and 1/8" up from bottom.

Assembly

1. To make the base, glue pieces **B**, **C** and **D** together. After glue has dried position box on piece **A** and attach. If nails are used, always pre-drill holes to prevent splitting.

2. Next glue and or nail drawer pieces together. The front of the drawer has rabbeted ends to fit over **B** pieces. Center knob on drawer front and screw in place.

3. Assemble coffee mill mechanism. Cover fits over bowl mechanism with stem of bowl facing up. Next, drop crank handle in place and tighten with cast iron nut and wing nut.

If using the wheel type grinder, the mechanism must be attached to the top (**E**) before the top is attached to the box.

To attach the mechanism to the top, the shaft and lower grinder unit must be apart from the bowl. Center bowl on top (**E**) to determine location of holes for the two machine threaded bolts. Note: Position top grinder so wheel is parallel to sides. Mark and drill 5/32" holes. Attach bowl.

The stem and lower grinder unit are then brought up from the bottom side of E. The flange on the lower grinder unit should be down. Attach lower unit to **E** with two small wood screws. (There will be a small gap between the flange and the underside of the top. This will be inside the box, will not be seen and will not interfere with the operation of the grinder.)

Complete assembly of mechanism before gluing Top (**E**) to the sides.

4. Sand and finish.

5. Place mechanism on base and screw in place.

Coffee Mill Materials

BASE:				
Part	Thick	Width	Length	Qty.
A Base	3/4"	6-1/8"	6-3/8"	1
B Sides	1/2"	4-5/16"	4-1/4"	2
C Front	1/2"	5"	2"	1

D Back	3/8"	5"	4-1/4"	1
E Top <i>(For Wheel Mechanism Only)</i>	3/4"	6"	6"	1

DRAWER:				
Part	Thick	Width	Length	Qty.
V Drawer Front	3/4"	5"	2-3/16"	1
W Drawer Side	3/8"	2-3/16"	3-7/8"	2
X Drawer Back	3/8"	2-3/16"	3-1/8"	1
Y Drawer Bottom	1/8"	3-3/4"	3-1/2"	1

Coffee Mill Dimensions

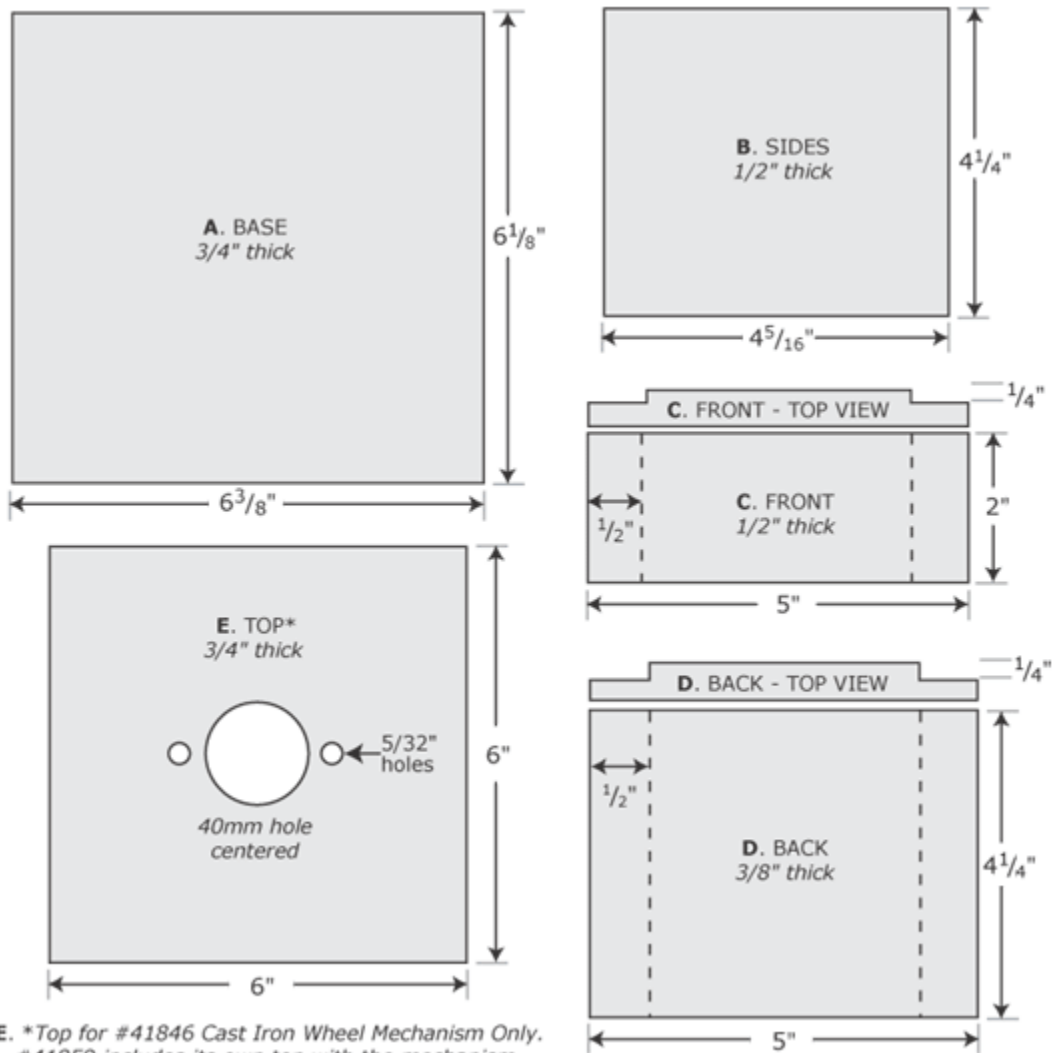

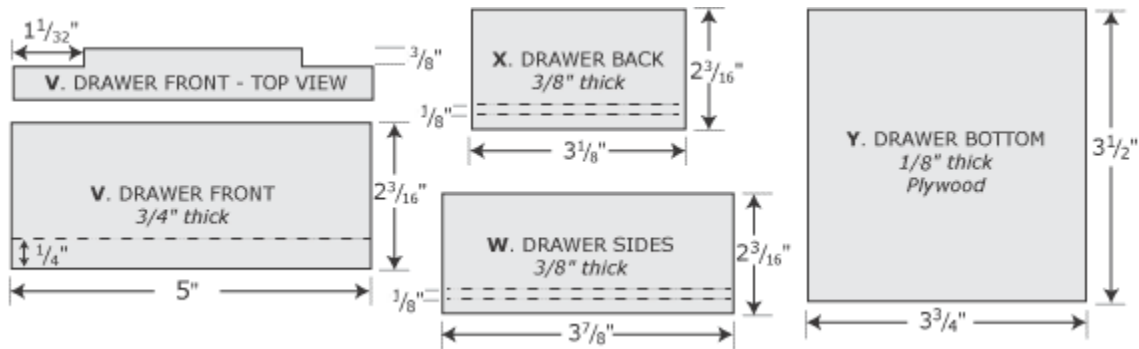

Special Instructions:

- Coffee Mill Mechanisms Sold Separately
- [Choose Cast Iron Wheel Grinding Mechanism](#) (#41846), or
- Traditional [Cast Iron Crank Grinding Mechanism](#) (#41859)
- No top (E) piece needed for Traditional Mechanism (#41859)
- Mechanisms are functional but intended for decorative use. A small amount of iron shavings may occur in the initial grinding process. These will decrease with use. To minimize the amount of shavings grind a first batch of beans on finest grind, discard grounds, then wash and dry the mechanism thoroughly before use. Paper filters are recommended when brewing.
- To order supplies with product #'s above, please call Rockler Woodworking and Hardware at 1-800-279-4441 or go online at www.rockler.com.



©Rockler Companies Inc, 2004